

Features

- High Efficiency (Up to 89%)
- Active Power Factor Correction (Typical 0.92)
- Constant Output Current
- Lightning Protection
- Waterproof (IP67)
- Dimming Control
- All-Round Protection: OVP, SCP, OLP
- Comply With UL8750 & EN61347 Safety Regulations
- Comply With FCC Part15 Class B



Description

The EUC-050SxxxDT Series operate from a 90 ~ 305 Vac input range. These units will provide up to a 4200 mA of output current and a maximum output voltage of 142 V for 50 W maximum output power. They are designed to be highly efficient and highly reliable. Features include over voltage protection, short circuit protection and over load protection.

Models

Output Current	Input Voltage	Max. Output Voltage	Max. Output Power	Typical Efficiency (1)	Power Factor		Model Number With Dimming Control (2, 3)	Model Number Without Dimming Control (2, 3)
					110Vac	220Vac		
4200 mA	90 ~ 305 Vac	12 Vdc	50 W	83%	0.98	0.92	EUC-050S420DT(6)	EUC-050S420ST(6)
3330 mA	90 ~ 305 Vac	15 Vdc	50 W	84%	0.98	0.92	EUC-050S333DT(6)	EUC-050S333ST(6)
2800 mA	90 ~ 305 Vac	18 Vdc	50 W	84%	0.98	0.92	EUC-050S280DT(6)	EUC-050S280ST(6)
2100 mA	90 ~ 305 Vac	24 Vdc	50 W	86%	0.98	0.92	EUC-050S210DT(6)	EUC-050S210ST(6)
1750 mA	90 ~ 305 Vac	29 Vdc	50 W	87%	0.98	0.92	EUC-050S175DT(6)★	EUC-050S175ST(6)
1400 mA	90 ~ 305 Vac	36 Vdc	50 W	87%	0.98	0.92	EUC-050S140DT(6)	EUC-050S140ST(6)
1100 mA	90 ~ 305 Vac	48 Vdc	50 W	87%	0.98	0.92	EUC-050S110DT(5)★	EUC-050S110ST(5)
700 mA	90 ~ 305 Vac	72 Vdc	50 W	87%	0.98	0.92	EUC-050S070DT(4)	EUC-050S070ST(4)★
450 mA	90 ~ 305 Vac	110 Vdc	50 W	88%	0.98	0.92	EUC-050S045DT(4)★	EUC-050S045ST(4)★
350 mA	90 ~ 305 Vac	142 Vdc	50 W	89%	0.98	0.92	EUC-050S035DT(4)★	EUC-050S035ST(4)★

- Notes:**
- (1) Measured at full load and 220 Vac input.
 - (2) The DT suffix may be changed to ST to omit the dimming function and remove the three wires associated with that function.
 - (3) A suffix -xxxx may be added to denote variations or modifications to the base product, where x can be any alphanumeric character or blank.
 - (4) Non-Class 2 output (USR & CNR).
 - (5) Class 2 output (USR), Non-Class 2 output (CNR).
 - (6) Class 2 output (USR & CNR).
 - (7) ★: Popular model.

Input Specifications

Parameter	Min.	Typ.	Max.	Notes
Input Voltage	90 V	-	305 V	
Input Frequency	47 Hz	-	63 Hz	
Leakage Current	-	-	0.5 mA	At 277Vac 50Hz input
Input AC Current	-	-	0.7 A	Measured at full load and 100 Vac input.
	-	-	0.35 A	Measured at full load and 220 Vac input.
Inrush Current	-	-	60 A	At 230Vac input 25°C Cold Start .

Specifications are subject to changes without notice.

Output Specifications

Parameter	Min.	Typ.	Max.	Notes
Output Current Range				
$I_o = 4200$ mA	3990 mA	-	4410 mA	
$I_o = 3330$ mA	3164 mA	-	3497 mA	
$I_o = 2800$ mA	2660 mA	-	2940 mA	
$I_o = 2100$ mA	1995 mA	-	2205 mA	
$I_o = 1750$ mA	1663 mA	-	1838 mA	
$I_o = 1400$ mA	1330 mA	-	1470 mA	
$I_o = 1100$ mA	1045 mA	-	1155 mA	
$I_o = 700$ mA	665 mA	-	735 mA	
$I_o = 450$ mA	428 mA	-	473 mA	
$I_o = 350$ mA	333 mA	-	368 mA	
Output Voltage Range				
$I_o = 4200$ mA	4 V	-	12 V	
$I_o = 3330$ mA	5 V	-	15 V	
$I_o = 2800$ mA	6 V	-	18 V	
$I_o = 2100$ mA	8 V	-	24 V	
$I_o = 1750$ mA	9 V	-	29 V	
$I_o = 1400$ mA	12 V	-	36 V	
$I_o = 1100$ mA	16 V	-	48 V	
$I_o = 700$ mA	24 V	-	72 V	
$I_o = 450$ mA	36 V	-	110 V	
$I_o = 350$ mA	47 V	-	142 V	
No Load Output Voltage				
$I_o = 4200$ mA	-	-	17 V	
$I_o = 3330$ mA	-	-	20 V	
$I_o = 2800$ mA	-	-	24 V	
$I_o = 2100$ mA	-	-	30 V	
$I_o = 1750$ mA	-	-	35 V	
$I_o = 1400$ mA	-	-	41 V	
$I_o = 1100$ mA	-	-	53 V	
$I_o = 700$ mA	-	-	77 V	
$I_o = 450$ mA	-	-	120 V	
$I_o = 350$ mA	-	-	154 V	
Ripple & Noise				
$I_o = 4200$ mA	-	-	5 V	Measurement is done by 20MHz bandwidth oscilloscope and the output paralleled a 104/500V ceramic capacitor and a 10uF/200V electrolysis capacitor
$I_o = 3330$ mA	-	-	5 V	
$I_o = 2800$ mA	-	-	5 V	
$I_o = 2100$ mA	-	-	5 V	
$I_o = 1750$ mA	-	-	5 V	
$I_o = 1400$ mA	-	-	5 V	
$I_o = 1100$ mA	-	-	5 V	
$I_o = 700$ mA	-	-	7 V	
$I_o = 450$ mA	-	-	11 V	
$I_o = 350$ mA	-	-	14 V	
Line Regulation	-	-	2%	
Load Regulation	-	-	5%	
Turn-on Delay Time	-	2.5 S	3.0 S	Measured at 110Vac input.
	-	1.5 S	2.0 S	Measured at 220Vac input.

Note: All specifications are typical at 25 °C unless otherwise stated.

Protection Functions

Parameter	Min.	Typ.	Max.	Notes
Over Voltage Protection				Hiccup mode. The power supply shall be self-recovery when the fault condition is removed.
$I_o = 4200 \text{ mA}$	16 V	17 V	18 V	
$I_o = 3330 \text{ mA}$	19 V	20 V	22 V	
$I_o = 2800 \text{ mA}$	23 V	24 V	26 V	
$I_o = 2100 \text{ mA}$	29 V	30V	32 V	
$I_o = 1750 \text{ mA}$	34 V	35V	37 V	
$I_o = 1400 \text{ mA}$	40 V	42 V	44 V	
$I_o = 1100 \text{ mA}$	52 V	54 V	56 V	
$I_o = 700 \text{ mA}$	76 V	78 V	80 V	
$I_o = 450 \text{ mA}$	116 V	118 V	120 V	
$I_o = 350 \text{ mA}$	154 V	156 V	158 V	
Over Load Protection	-	1.25 Vmax	-	Hiccup mode. The power supply shall be self-recovery when the fault condition is removed.
Short Circuit Protection	No damage shall occur when any output operating in a short circuit condition. The power supply shall be self-recovery when the fault condition is removed.			

General Specifications

Parameter	Min.	Typ.	Max.	Notes
Efficiency				Measured at full load and 110 Vac input.
$I_o = 4200 \text{ mA}$	79%	80%	-	
$I_o = 3330 \text{ mA}$	80%	81%	-	
$I_o = 2800 \text{ mA}$	81%	82%	-	
$I_o = 2100 \text{ mA}$	83%	84%	-	
$I_o = 1750 \text{ mA}$	84%	85%	-	
$I_o = 1400 \text{ mA}$	85%	86%	-	
$I_o = 1100 \text{ mA}$	85%	86%	-	
$I_o = 700 \text{ mA}$	85%	86%	-	
$I_o = 450 \text{ mA}$	86%	87%	-	
$I_o = 350 \text{ mA}$	87%	88%	-	
Efficiency				Measured at full load and 220 Vac input.
$I_o = 4200 \text{ mA}$	82%	83%	-	
$I_o = 3330 \text{ mA}$	83%	84%	-	
$I_o = 2800 \text{ mA}$	83%	84%	-	
$I_o = 2100 \text{ mA}$	85%	86%	-	
$I_o = 1750 \text{ mA}$	86%	87%	-	
$I_o = 1400 \text{ mA}$	86%	87%	-	
$I_o = 1100 \text{ mA}$	86%	87%	-	
$I_o = 700 \text{ mA}$	86%	87%	-	
$I_o = 450 \text{ mA}$	87%	88%	-	
$I_o = 350 \text{ mA}$	88%	89%	-	
No Load Power Dissipation	$\leq 6 \text{ W}$			
MTBF	487,000 hours			For 4200 mA output model, measured at 110Vac input, 80%Load and 25° C ambient temperature (MIL-HDBK-217F).
Life Time	66,000 hours			For 4200 mA output model, measured at 110Vac input, 80%Load and 45° C ambient temperature
Dimensions				
Inches (L x W x H)	6.77 x 1.36 x 1.67			
Millimeters (L x W x H)	172 x 34.5 x 42.5			
Net Weight	-	480 g	-	

Note: All specifications are typical at 25 °C unless otherwise stated.

Specifications are subject to changes without notice.

Environmental Specifications

Parameter	Min.	Typ.	Max.	Notes
Operating Temperature	-35 °C	-	+55 °C	Humidity: 10% RH to 100% RH
Storage Temperature	-40 °C	-	+85 °C	Humidity: 5% RH to 100% RH

Safety & EMC Compliance

Safety Category	Country	Standard
CUL	USA & Canada	UL8750, UL935, UL1012, UL1310 Class 2, CSA-C22.2 No. 107.1, CSA C22.2 NO. 223-M91 Class 2
CE	Europe	EN 61347-1, EN61347-2-13
EMI Standards	Country	Notes
EN 55015	Europe	Conducted emission Test & Radiated emission Test with 6 dB margin
FCC	USA	FCC Part 15 Class B, ANSI C63.4: 2009.
EMS Standards	Notes	
EN 61000-3-2	Harmonic current emissions	
EN 61000-3-3	Voltage fluctuations & flicker	
EN 61000-4-2	Electrostatic Discharge (ESD): 8 kV air discharge, 4 kV contact discharge	
EN 61000-4-3	Radio-Frequency Electromagnetic Field Susceptibility Test-RS	
EN 61000-4-4	Electrical Fast Transient / Burst-EFT	
EN 61000-4-5	Surge Immunity Test: AC Power Line: line to line 2 kV, line to earth 4 kV	
EN 61000-4-6	Conducted Radio Frequency Disturbances Test-CS	
EN 61000-4-8	Power Frequency Magnetic Field Test	
EN 61000-4-11	Voltage Dips	
EN 61547	Electromagnetic Immunity Requirements Applies To Lighting Equipment	

Derating Curve

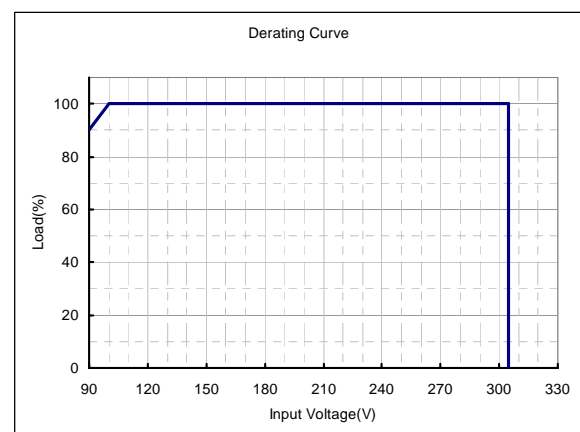
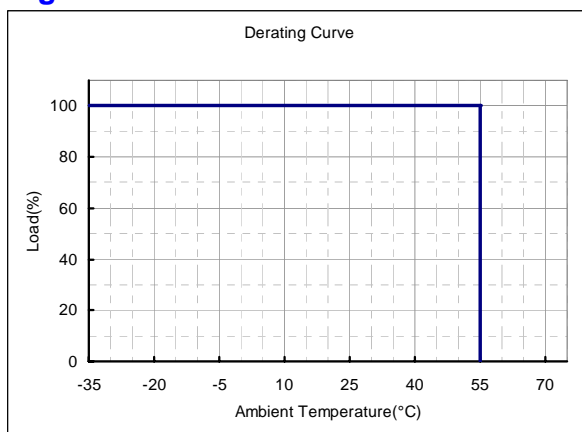

Specifications are subject to changes without notice.

Mechanical Outline

EUC-050SxxxST

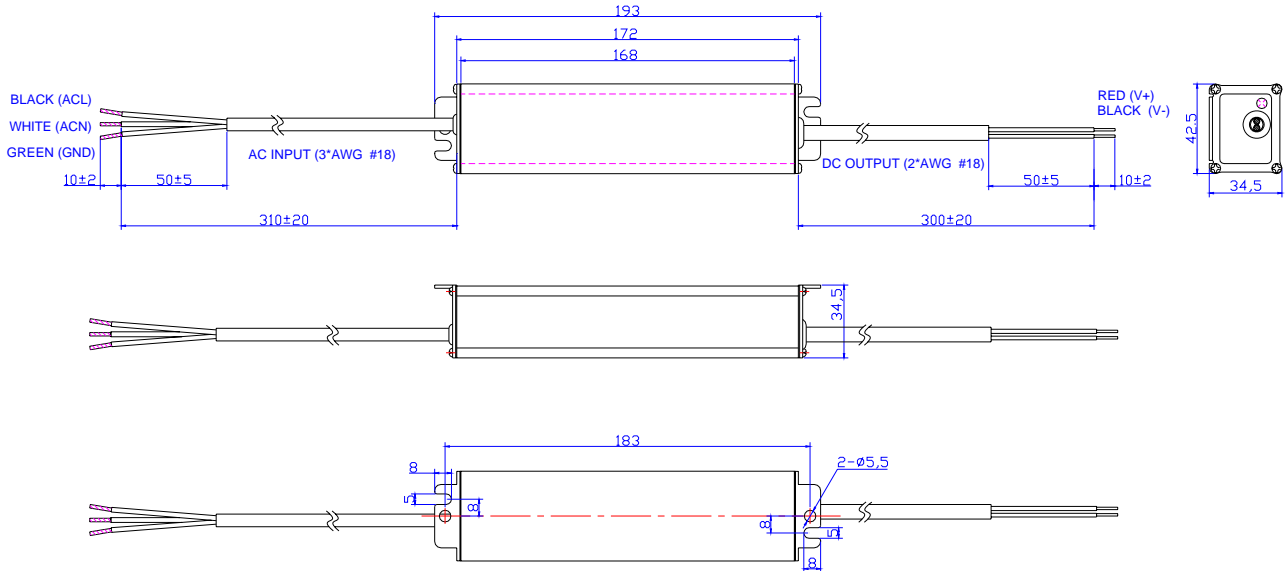

EUC-050SxxxDT

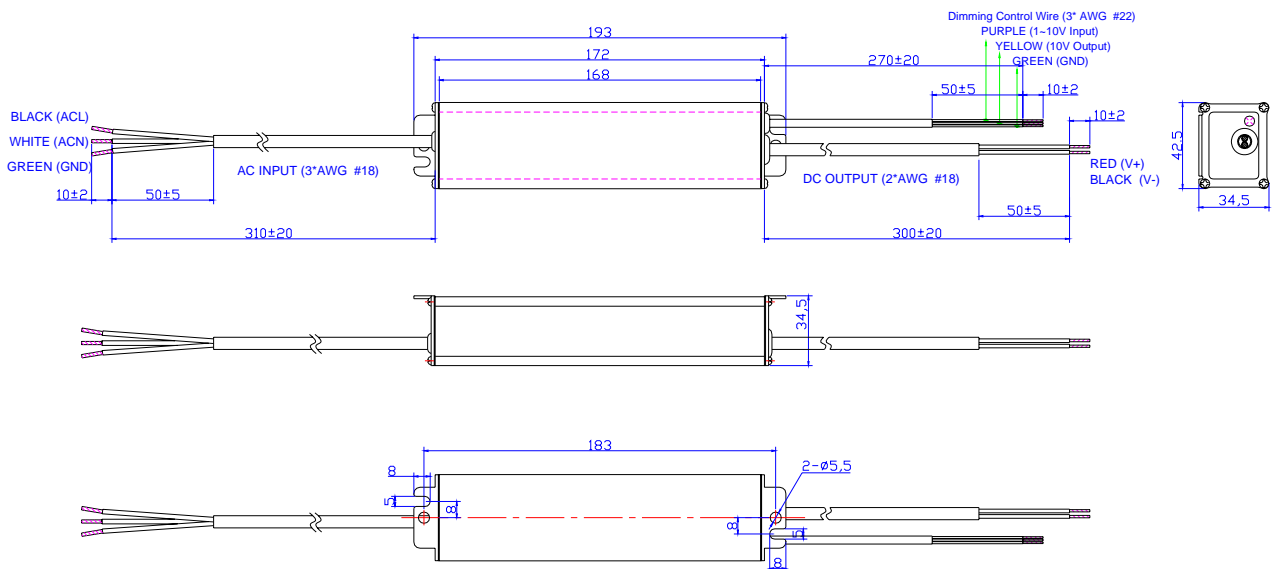

Specifications are subject to changes without notice.

Dimming Control (On secondary side)

Parameter	Min.	Typ.	Max.	Notes
10V output voltage	9.8 V	10 V	10.2 V	
10V output source current	-10 mA	-	2 mA	
Absolute maximum voltage on the 1~10V input pin	-2 V	-	15 V	
Source current on 1~10V input pin	0 mA	-	1 mA	

The dimmer control may be operated from either a potentiometer or from an input signal of 1 – 10 Vdc. Two recommended implementations are provided below.

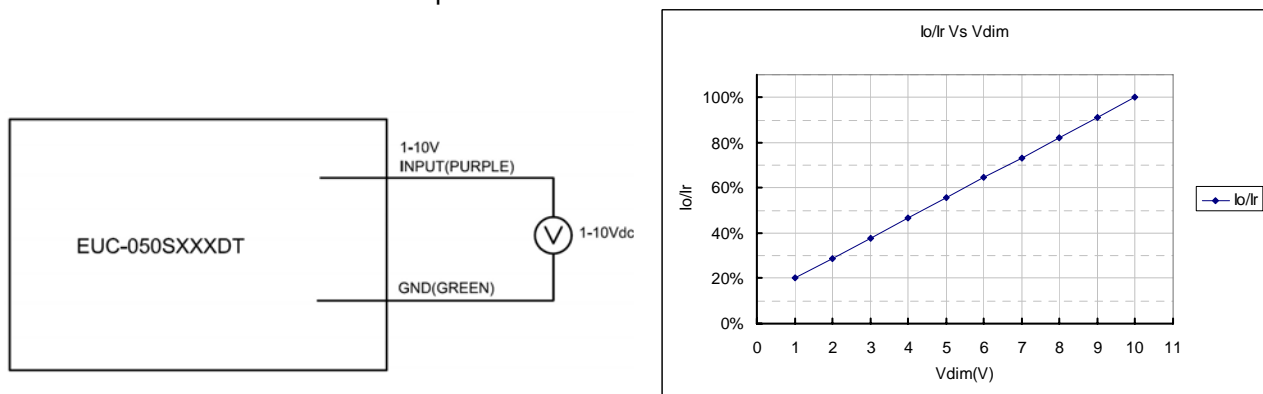
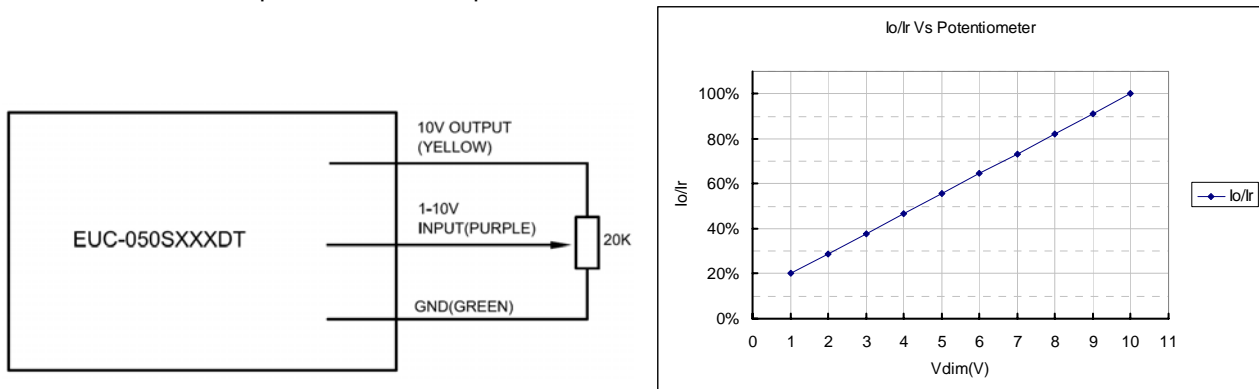

Notes:

1. I_o is actual output current and I_r is rated current.
2. If the dimming function is not used, please short 10 V output pin (yellow) and 1-10 V input pin (purple).
The output current is about 92% I_r when the 1-10V input pin is floating.
3. For the driver to operate properly, the load voltage must be maintained above the minimum voltage threshold (approx. 33% of the max. output voltage for any given model).
4. The dimming voltage can be tuned down to less than 1V, and the output current will be decreased to about 10% I_r ; but the connected LEDs may flicker. Keeping dimming voltage greater than 1V in application is strongly recommended.
5. Do not connect the GND of dimming to the output; otherwise, the LED driver can not work normally.

RoHS Compliance

Our products comply with the European Directive 2002/95/EC, calling for the elimination of lead and other hazardous substances from electronic products.

Specifications are subject to changes without notice.

Revision Record

Change Date	Rev.	Description of Change						
		Item	From			To		
2009-09-02	V2.1	Change MTBF and Life Time						
2009-09-11	V2.2	Change Turn-on Delay Time						
2009-12-08	A	Modify the PF value, no-load power dissipation, dimming range						
2010-01-12	B	Modify the derating curve and mechanical outline						
2010-04-12	C	Change the Power Factor						
			110Vac	0.99			0.98	
			220Vac	0.94			0.92	
		Add Leakage Current in Input Specifications	/			Max. 0.5 mA At 277Vac 50Hz input		
		Change Inrush Current	20A			60A		
		Add No Load Output Voltage	/			The max. value of every model.		
		Change Ripple and Noise	Max. 25% V _O			The max. value of every model.		
		Change Turn-on Delay Time	110Vac	Typ. 1.7S	Max. 2.0S	Typ. 2.5S	Max. 3.0S	
			220Vac	0.7S	1.0S	1.5S	2.0S	
		Delete Output Overshoot / Undershoot	Max. 10%			/		
		Change Over Load Protection	Typ.: 1.25P _o			Typ.: 1.25 V _{max}		
		Delete part of the notes in Operating Temperature	Derating: 2% per °C from 55°C to 70°C.			/		
Change the Max. Ambient Temperature in Derating Curve	+70 °C			+55 °C				
Change linearity of dimming curve	/			/				
Change the notes in Dimming Control	/			/				
2010-05-31	D	Add star rank for recommended models	/			☆: Popular model.		
2010-10-14	E	Change the notes in Dimming Control	/			/		
2011-1-10	F	Change popular models	/			/		
		Change No Load Output Voltage	Max. 122V			Max. 120V		
		Change Over Voltage Protection	Min.	Typ.	Max.	Min.	Typ.	Max.
		I _o = 4200 mA	14V	16V	18V	16V	17V	18V
		I _o = 3330 mA	18V	20V	22V	19V	20V	22V
		I _o = 2800 mA	22V	24V	26V	23V	24V	26V
		I _o = 2100 mA	30V	32V	34V	29V	30V	32V
		I _o = 1750 mA	36V	38V	40V	34V	35V	37V
		I _o = 1400 mA	40V	41V	42V	40V	42V	44V
		I _o = 1100 mA	57V	58V	59V	52V	54V	56V
I _o = 700 mA	92V	94V	96V	76V	78V	80V		
I _o = 450 mA	141V	143V	145V	116V	118V	120V		
I _o = 350 mA	183V	185V	187V	154V	156V	158V		
Add FCC Part15 Class B	/			FCC Part 15 Class B, ANSI C63.4: 2009.				

Specifications are subject to changes without notice.